



ELECTRICAL AND AUTOMATION SYSTEM

FOR POWER GENERATION AND TRANSMISSION

LAGOS





One of the most significant necessities of today, electric power has become a value that needs to be monitored carefully from production to consumption. This is primarily due to rate of depletion of fossil fuels and the challenge of global warming the world is facing. Producing electricity at relevant costs, minimizing the impact on the environment during production and delivering power to users at high quality standards with minimum losses are the most critical issues of today.

Older power production technologies did not offer the benefits of modern technologies currently in use. Consequently, losses occur with these systems at all stages from manufacturing to consumption and impact on the environment is consistently at high levels. On the other hand, use of „smart“ automation systems and advanced electrical infrastructures in modern energy generation and transmission systems can contribute to improved productivity and energy quality as well as decreased losses.

Another issue that needs addressing is generating maximum amount of power with minimum cost. Optimization in energy, power generation and transmission systems have become a significant factor for protecting world’s natural resources that are depleted at a fast pace.

Furthermore, information management systems including management of data from power generation and transmission systems provide advantages in terms of preventing faults, quickly eliminating interruptions and reporting of events.

At Lagos Energy, we help increase the performance and productivity of power plants, we provide facilities for monitoring and security of switchyards and help delivery of electricity with the lowest possible losses. We achieve these by means of automation systems and electrical infrastructures we design and implement specifically to meet the requirements of our customers operating in the energy sector.



ABOUT US

As one of the leading engineering companies in Turkey, Lagos Energy has successfully installed and delivered a number of projects in a relatively short time. Dynamism and experience of our team at Lagos Energy has challenged and accomplished local and international projects with great success.

Lagos Energy builds and installs panels and other essential hardware for its solutions within its own capacities; which is the underlying factor behind its policy of high quality turn-key solutions delivered to customers.

Lagos Energy is taking firm steps in becoming a global brand with its continuous strive in expanding its products and systems range, employing the most current technologies.

Having its headquarters in Ankara, Lagos Energy offers a range of projects and services, targeted for its customer base at home and abroad and intended at effective use of energy resources. To achieve this, the quality of data we measure and collect is important. We have a broad range of testing and measuring equipment that allows us to collect the most accurate data.

OUR SERVICES

General services

- Design and analysis of power systems
 - Short circuit analysis
 - Load flow analysis, load-shedding
 - Stability analysis, transition stability, voltage stability
 - Relay coordination, selectivity analysis
 - Harmonic analysis, electromagnetic transition analysis
 - Design of power systems
 - Grid quality, interconnection works
 - Frequency regulation
 - Power system stability
 - Mathematical modeling of power plants
- Energy SCADA solutions
- Balance of Plant (thermal, natural gas, hydroelectrical)
- IEC 61850 and communications applications
- Applications for industrial processes (DCS, Distributed Control System)
- Power quality analysis and modeling
- Power plants TEİAŞ RTU and communication solutions
- Power plants TEİAŞ auxiliary services solutions (Primary and secondary frequency control, reactive power control)
- Substations; secondary project, relay, panel, and SCADA solutions
- Electrification solutions for transportation and rail systems
- Panel solutions

Services we provide for power generation plants

- Design and procurement of control systems
 - Architectural design of control systems
 - Equipment selection of control systems
 - Design and manufacturing of control panels
 - Supply of hardware and software panels
- Control systems implementation
 - PLC/DCS programming
 - Configuration of hardware/software
 - HMI/console engineering
 - FAT (factory acceptance tests)
- Control systems, start-up and commissioning
 - SAT (site acceptance tests)
 - Commissioning
 - Field services
- Process control engineering
 - Functional logic descriptions and logic diagrams
 - Control systems specifications
 - Instrument design, instrument specifications and data sheets
 - Instrument connection diagrams
 - Instrument list, cable list, signal list, alarm list
 - Loop cabling diagrams



Basic engineering and consultancy services for power plants

- Performance evaluation, testing, review of power plants
- Electrical single line diagrams
- Field layout
- Process flowcharts control and review
- P & I diagrams control and review
- Auction Technical Specifications specifications control and review
- Performance test procedures for power plants,

Detailed engineering and consultancy services for power plants

- P & ID equipment coding (ISA/KKS) and I & C control
- Electrical load list
- MCC control circuit diagrams
- Lists and connections of instruments, signals, and cables
- Instrument assembly documentation
- Instrument design and technical spec.s
- Function descriptions and logic diagrams
- Control panel design
- Evaluation of price offer for relevant equipment and systems

Services we provide for power transmission systems

- Short circuit calculations
 - In accordance with IEC60909 standard, computer aided calculation of maximum and minimum 1 phase, phase-phase and 3 phase short circuit currents that may occur in busbars
- Calculation of parameters for relays to be used in the system according to the selectivity which will be used in the system as a result of short circuit analysis
- Drawing short circuit and thermal resistance curves of transformers on graph paper
- Drawing short circuit and thermal resistance curves of MV cables on graph paper
- Marking minimum short circuit currents to occur in the system on the graph paper
- Advanced and detailed reporting
- Monitoring tripping times of relays automatically by simulating the failures
- Selection of MV power cables (check with respect to voltage drop, current carrying, and short circuit)
- Load flow study
- Transient stability study
- Calculation of setting values of motor protection relays
- Calculation of setting values of generator protection relays
- Inspection of behavior of the system during operation of high power motors
- Calculation of transformer power
 - Calculation of lighting voltage drop
 - Lightning rod (lightning protection) calculations
 - Neutral resistance sizing
 - Conductor cross section calculation
 - Earthing calculations
 - Current transformer sizing
 - Current-rectifier selection
 - Determining relay coordination and relay setting values



A photograph of a power plant facility situated along a body of water. The scene features several tall, cylindrical smokestacks with red and white horizontal stripes. To the right, there are large, white cooling towers, one of which has the word 'RYEN' visible on its side. The plant's main buildings and piping are visible in the middle ground. The sky is clear and blue, and the water in the foreground reflects the structures and the sky. The text 'Electrical and automation system in power plants' is overlaid in white on the bottom left of the image.

Electrical and
automation system
in power plants



Monitoring, controlling and reporting of all components of the generation process in power plants are all critical factors for producing high quality power with lowest possible loss and cost.

By effective use of control systems and electrical infrastructure we install based on the type and capacity of your power plant, we help you to realize your return on investments within a short period of time.

The two basic infrastructure systems and services we provide for power plants are; automation systems and electrical systems.

These systems are further described in detail in proceeding pages.

Automation systems

- Balance of plant
- Control systems
- PLC systems
- Compact DCS systems
- Advanced DCS systems
- SCADA systems
- Turbine control and protection systems

Electric systems

- Synchronization
- Protection systems (generators, turbines and transformers)
- Excitation systems, automatic voltage regulators (AVR)
- Static starter system
- Measurement

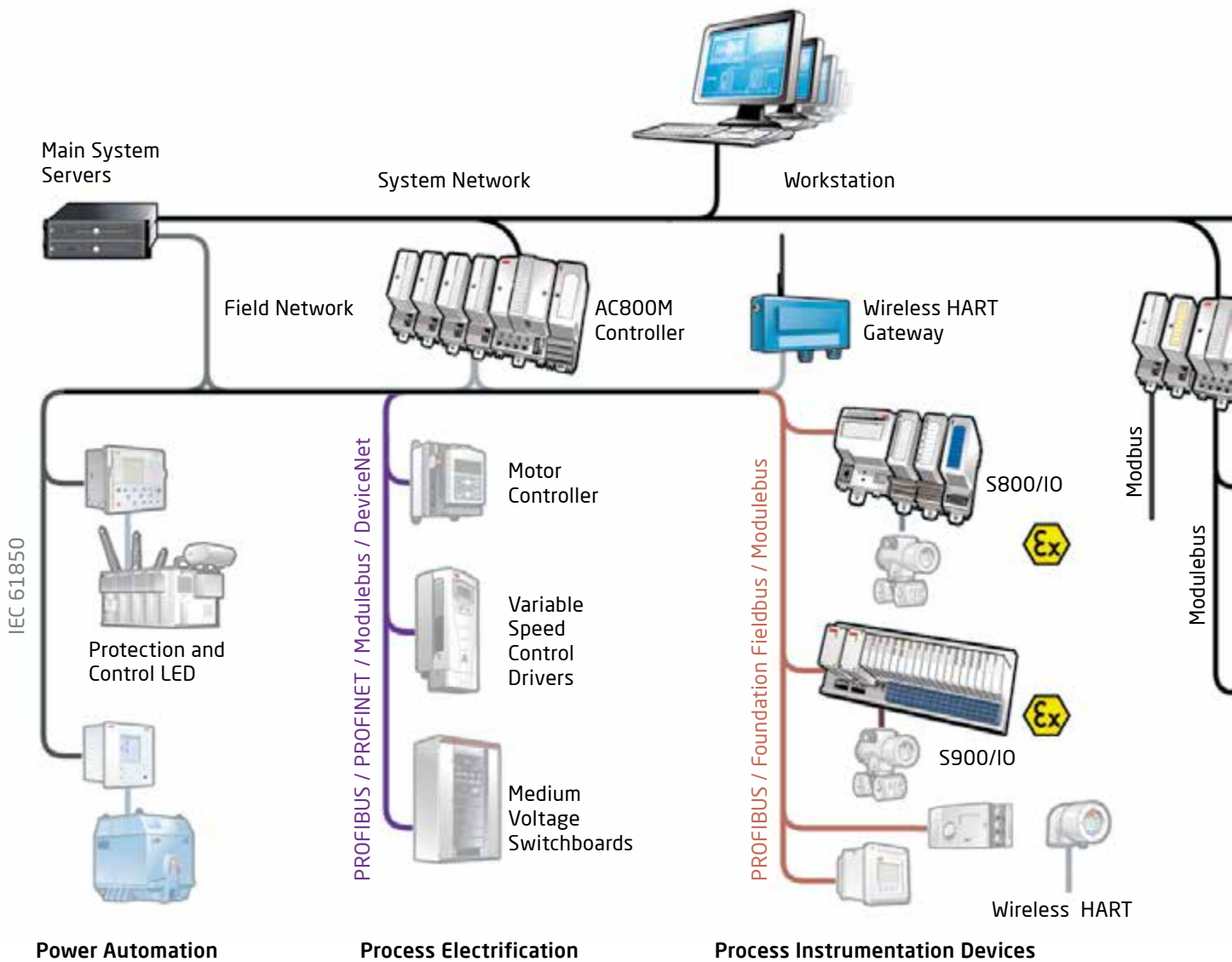

AUTOMATION SYSTEMS IN POWER PLANTS

Automation and control systems enable efficient and safe operation of power plants by minimizing the risks. Monitoring and reporting ensure the opportunity to access all control points from any given point in the system as well as flexibility, speed and minimized faults. Lagos Energy maximizes automation through "Balance of Plant" integration, control systems and turbine control systems specifically designed for your facility.

System architecture

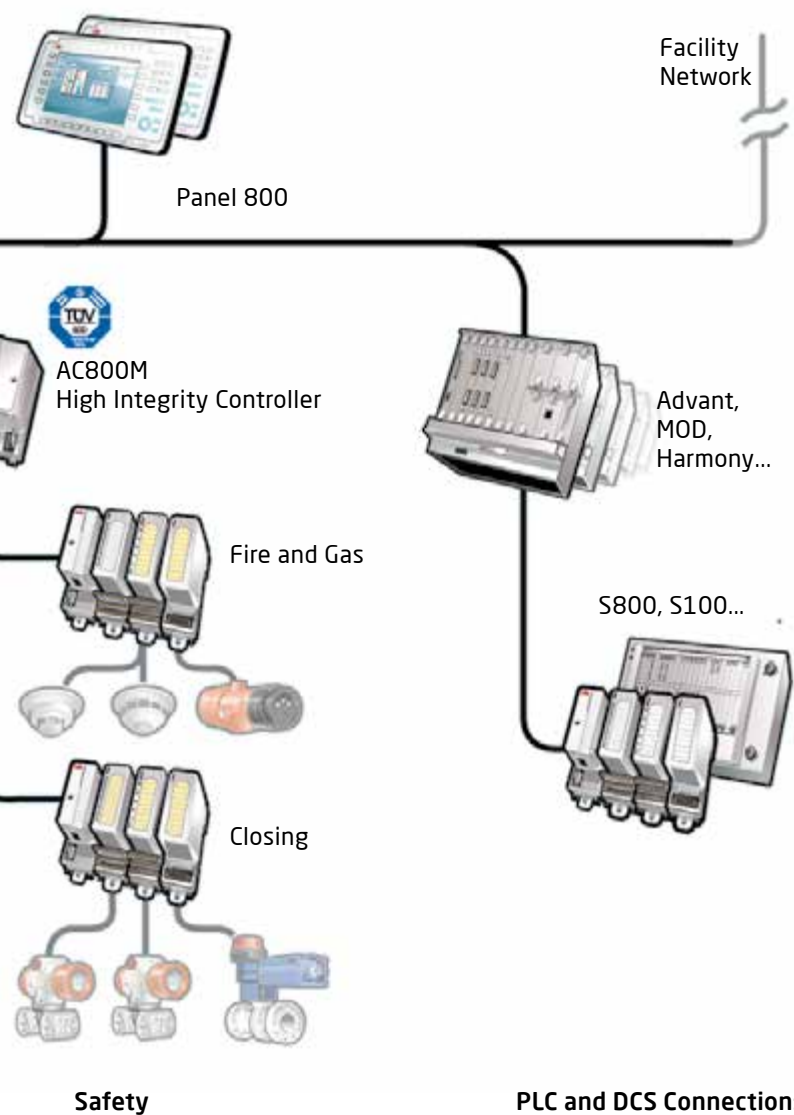

Contributions of automation systems for power plants

- Opportunity to access all control parameters from any point in the system
- Managing and monitoring the entire system from a single control platform
- Rapid command issuing
- Integration of electric infrastructure and automation systems
- Prior determination and prevention of unexpected faults and reduction of maintenance time
- Secure data acquisition and fast data flow

BALANCE OF PLANT

Independent from the type of your power plant, our experience and engineering know-how allows us to provide "Balance of Plant" integration specific to your installations and turn-key system integration.

Balance of Plant includes systems, components and structures in a power plant other than the main generation system and heat recovery systems (e.g. gas turbines, steam turbines...). BOP aims to combine various independent control systems on a single platform.

Integration of these systems in an optimum way, ability to share data among systems and the flexibility introduced by this system are important parameters leading to the efficiency and productivity of a power plant.

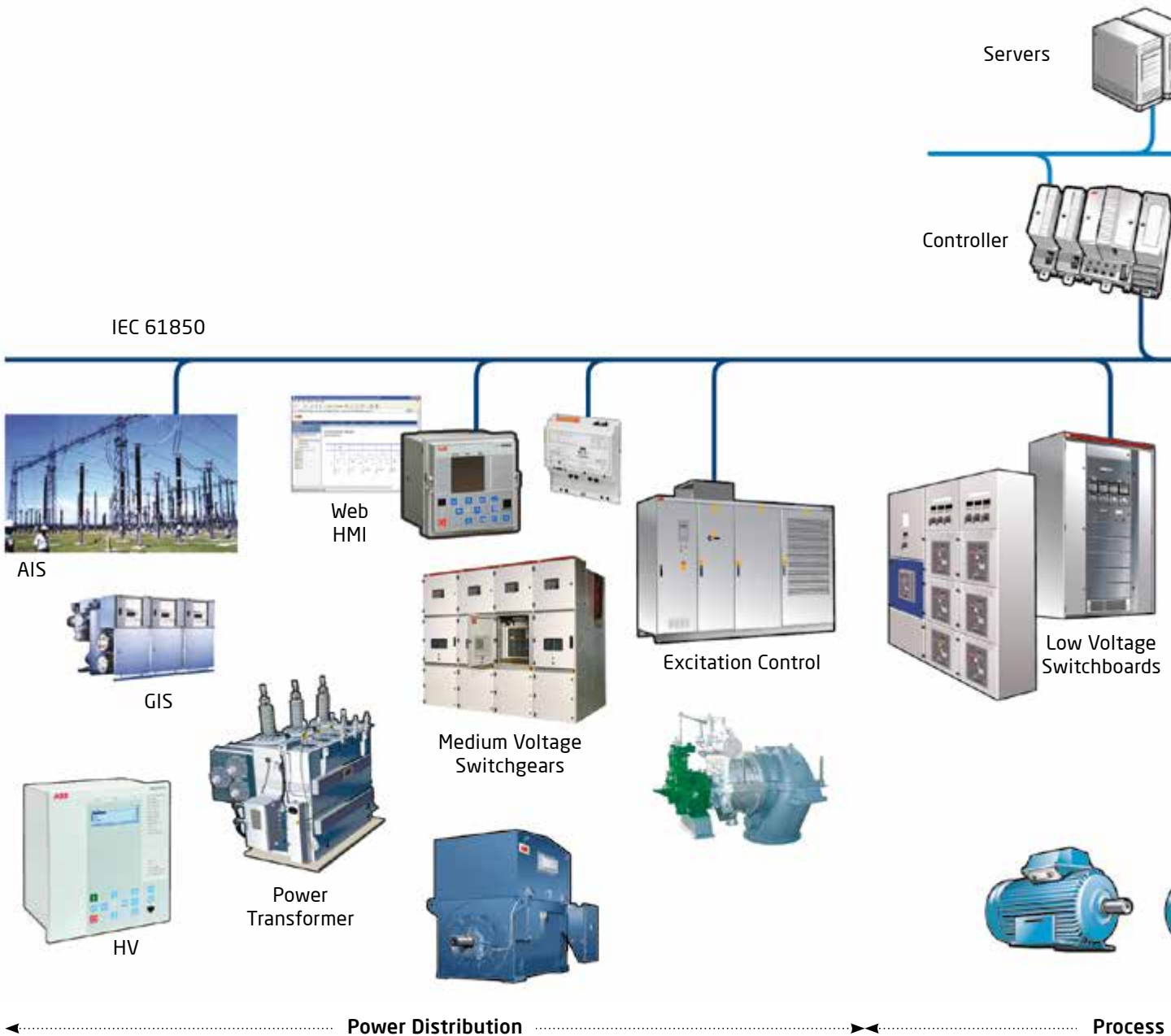

Services we provide within the Balance of Plant package

- Modulation control
- Sequence control
- Boiler burning control
- Feed water pump control
- Boiler safety supervision
- Data acquisition
- Electrical system control
- "Balance of Plant" equipment control
- Stack gas desulphurization control
- Turbine control
- Turbine supervision instrumentation devices
- Combined Cycle control
- Emergency shutdown
- Data transfer to ERP system
- Boiler optimization
- System efficiency map

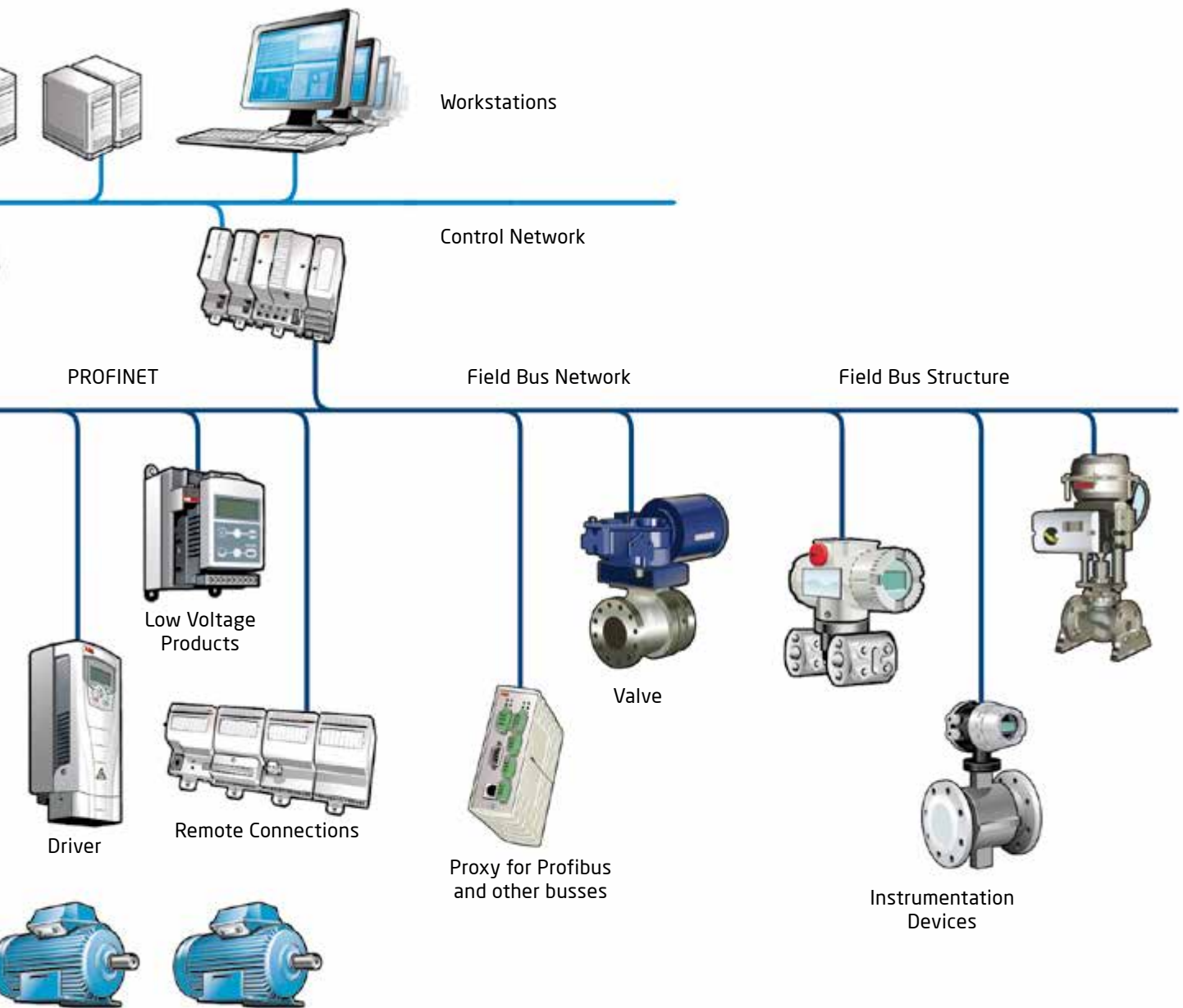

BALANCE OF PLANT

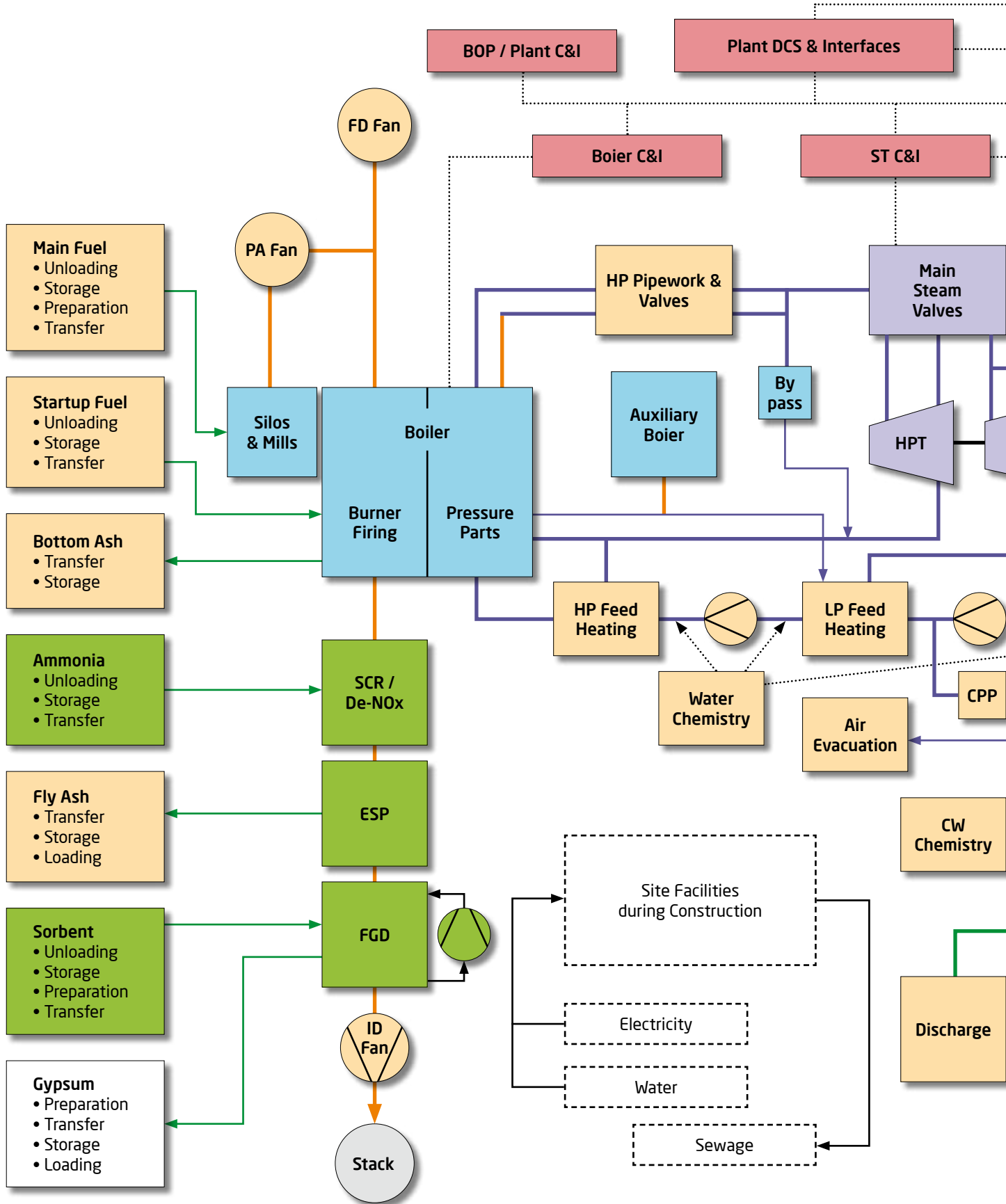

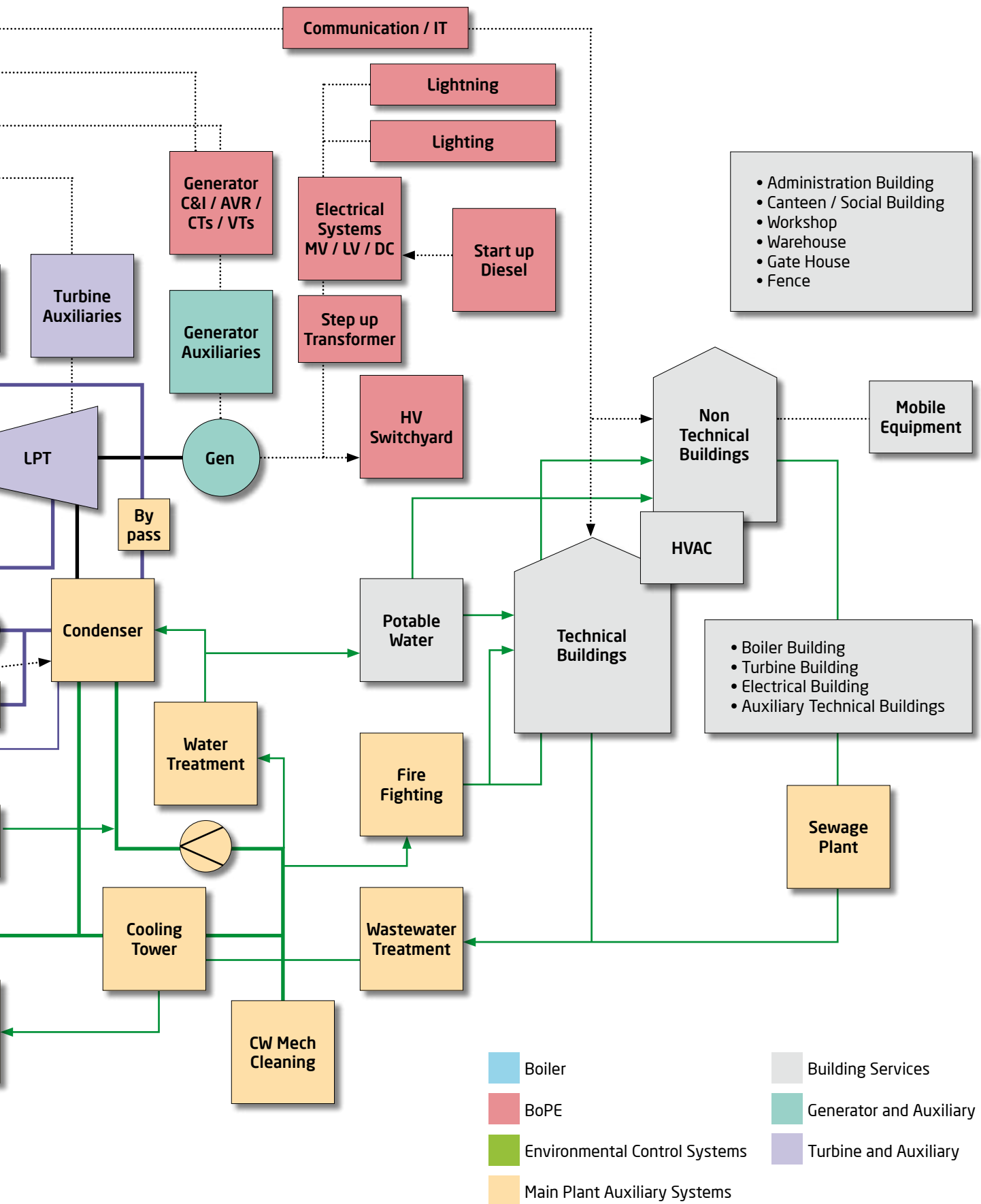

CONTROL SYSTEMS

With its ability to work on standard computer hardware, in addition to control systems such as DCS, PLC as well as capability to convert all control parameters into visual control tools, SCADA software makes it possible to expand the system to meet changes in future requirements.

PLC Systems

PLC offers maximum speed and efficiency in production processes and is an ideal solution for a multitude of automation needs; from simple to complex that require high performance, low cost and flexibility. ABB's AC500 automation platform for PLC applications is capable of meeting these ever increasing customer requirements. With its scalable architecture, AC500 secures your investment. Managing more than one field bus with a single control system, user-friendly structure, easy configuration and ample communication possibilities are other significant advantages provided by AC500 PLC to our customers.



Based on open protocol, SCADA is hardware and manufacturer independent and therefore capable of expanding to meet future requirements. It contributes to facilitating reporting and detailed analysis, minimizing faults, evaluation and improvement on energy efficiency and system performance.

Compact DCS Systems

Compact and scalable DCS systems -in addition to providing powerful automation functions- present low cost advantage for hardware and software. Ensuring minimum engineering and maximum automation facilities, ABB Freelance compact DCS systems have open and modern system architecture. With its distributed architecture installed at the field by controllers, it can effectively reduce cabling costs. Freelance requires single software for application engineering, commissioning and fault finding and therefore can be fully integrated into field bus management control system. Visual components pre- engineered for operators are one of many advantages to users.





Advanced DCS Systems

Advanced DCS systems are used for accessing multiple applications and multiple data from any workstation located at any point at the power plant. ABB System 800xA advanced DCS systems increases productivity as well as decreasing risks and costs.

Integrated engineering infrastructure of the System 800xA minimizes complexities from planning to configuration and from library management to commissioning, and offers savings by supporting lifespan of automation projects. Compliant with IEC 61508 and IEC61511, System 800xA provides security for the entire system and minimizes the risk ratio. Powerful reporting feature enables reporting by processing any process related information. The advanced planning feature of System 800xA allows a multitude of different requirements for increasing production, to be identified beforehand. Also, continuously monitoring the state of equipment in a power plant with System 800xA allows for preventive maintenance which is important to achieve investment optimization.

Advantages offered by System 800xA in energy production

- A platform that can meet future process and electrical systems requirements
- Capable of meeting IEC 61850 requirements
- User-friendly user interface
- Ability to access from any point outside the facility
- Quick fault analysis capability
- Outstanding engineering skills and quality
- Low budget operation and management
- Simple system architecture
- Unique technology and integration with existing systems

SCADA SYSTEMS

SCADA (Supervisory Control and Data Acquisition) system basically consists of human-machine interfaces (HMI), host and client computer systems, remote terminal units (RTU), DCS and PLCs, various communication structures, and different instruments.

HMI is the interface that provides process data to the operator and therefore allowing the operator to monitor and control the process. RTU is the unit that provides connection with sensors in the process, converts sensor signals into digital signals and sends these signals upstream to the system. PLC is a configurable and flexible field device that performs similar functions locally.

Created as a visual control platform intended for all supervision, control and monitoring, SCADA can be present on one or more networks together with sub-systems mentioned above. This structure allows SCADA quick and easy access to process data and helps taking precaution against potential faults.

The entire control architecture covering a number of systems can be transferred to SCADA over DCSs; such as turbine and boiler control, cooling systems control, monitoring coal transportation line, switchyard and MCC panels, controlling condensers and analyzing gases in a power plant etc.





In addition to control functions, SCADA offers many facilities such as monitoring events and alarms, examining and reporting information retrospectively, providing information to remote operators via GSM networks. Production report drafts required by electric utilities companies can be prepared beforehand with reporting function and automatically created at desired intervals (daily, weekly, monthly, etc.). Also, "predictive maintenance" can be made by monitoring operation times and alarms of actuators such as breakers, engines, pumps, valves located in the field. In this way, faults which may occur can be estimated, and down times may be shortened. With Thin Clients or Web Clients, state of the system can also be monitored from any remote point outside of the plant.

TURBINE CONTROL AND PROTECTION SYSTEMS

Turbines are at the heart of the electric generation process and play an active role for converting mechanical energy into electric energy. Turbines can be classified as steam, gas, hydro and wind turbines according to the energy resources they require. Parameters that are controlled in a turbine control system may be adapted based on the type of energy resource. As an example, for the purpose of continuous and quality energy production in thermal power plants, it is necessary to control and monitor different parameters such as water amount and water circulation, control of feed-water, boiler water temperature, amount of fuel, pressure, igniter control system, water cooling system, all the way from burning fuel stage to obtaining steam and turning turbines.

Turbines can be controlled with PLCs or dedicated control devices. These systems perform critical closed-loop algorithms such as speed and load control. Apart from general SCADA interface for controlling and monitoring, alarm and reporting functions can be provided with a local and dedicated interface. Data obtained from the site can be transferred into SCADA system.

Benefits

- Low lifespan cost
- Optimized operation
- Excellent reliability
- Increased turbine lifespan via sensitive controls
- Short commissioning time
- Decreases in fault costs and repair times
- Fully automated operation eliminating operator errors
- Quick access to information

For Turbine Control Systems, we use ABB AC800M and AC870P solutions and Woodward turbine control solutions.





Turbine protection systems and valve positioning products are additional components supplementing the system. Speed, the most critical parameter for rotating parts, is continuously monitored. Protection systems are connected to other field devices such as speed measurement devices and servo valves in turbines. These provide over speed protection and valve

positioning controls independent from main control. Turbines are protected and their lifespan is extended by monitoring many critical parameters such as speed, oil pressure, temperature, etc. As a result, a quicker, more flexible, functionally enriched turbine control system is obtained.

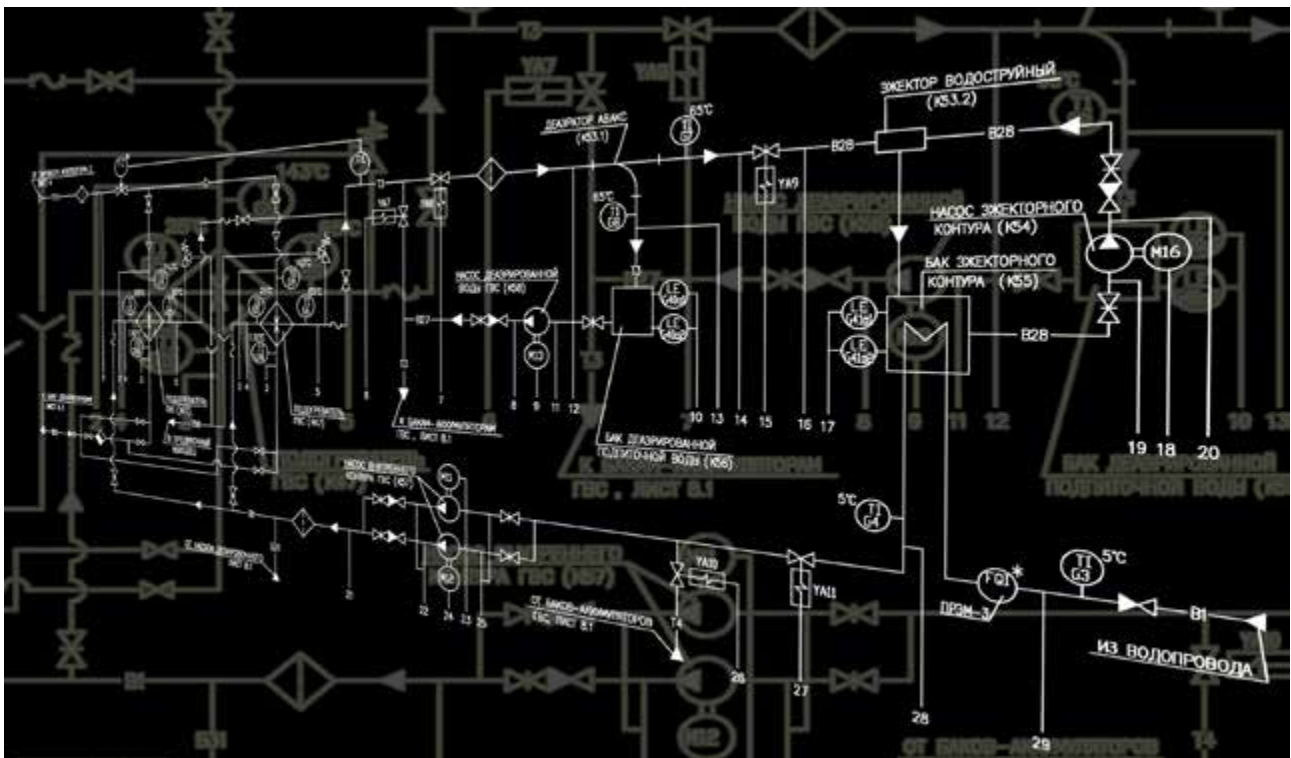

ELECTRIC SYSTEMS IN POWER PLANTS

Facilities need qualified and trained human power, large investment expenses and technologies in order to meet the increasing demand for energy. At this point, automation and smart electric infrastructure is now an indispensable characteristics.

Lagos Energy installs turn key excitation systems, generator protection systems, synchronization systems, energy invoicing/automated meter reading systems.

Furthermore, as additional services we implement various applications such as primary and secondary frequency control systems, reactive power control systems.

Main applications

- Synchronization
- Protection systems
 - Generator
 - Turbine
 - Transformer
- Excitation systems, automatic voltage regulators (AVR)
- Static starter system
- Measurement
- Network connection and power quality
- MCC panel systems



SYNCHRONIZATION

Generator synchronization systems are devices for providing network and generator safety and security that are generally used in power generation facilities, industrial facilities such as cogeneration facilities, marine industry, hospitals, shopping centers and hotels. The main purpose of using generators is to minimize power interruption time and keep continuous power where connection is available.

The main function of generator synchronization systems is to transfer energy from the network to the generator or in reverse case to ensure transition of supplied energy with synchronized amplitude, phase angle and frequency. Otherwise overloading can occur at the network or generator, irregularities may occur at the network, breakers may open or generators may be damaged.

The main purpose of performing the synchronization process is to automatically or manually ensure network and generator security.

During synchronization process, in case a fault occurs on one of the serially connected channels in a "dual

channel" application, the other channel is also blocked. This configuration increases security. In applications with "back-up", in case of any fault anyone of the parallel connected devices, the other one overtakes the function and ensure its continuous operation.

SYNCHROTACT product range from ABB is a device preventing switching in asynchronous mode where there is significant difference between voltage and phase angles. Prior to connecting these systems, SYNCHROTACT brings voltage and speed of generator to automatically adjusted tolerance interval taking into account voltage, frequency, phase angle and breaker switching time. Digital dual channel and redundant synchronization systems provide high level of reliability.



PROTECTION SYSTEMS

In a power plant, generators and transformers are units that are the most likely to have faults and thus they should be protected in the best manner. Generator protection includes transformers and auxiliary transformers in addition the generator itself. In principle the generator protection includes determining faults and irregular states within the shortest possible time and minimizing damages that may occur.

Regardless of the generator type, we provide the most efficient electric infrastructure as well as secure and economic systems integration by establishing the criteria in which a generator can work securely and efficiently.

We use ABB protection units which have modular hardware, have flexible structure, and utilize

microprocessor based technology. Protection functions can be selected taking suitable redundancy into account. This enables reliable, secure and economic functioning of the generators.

Relion product range designed by ABB for generator protection provides wide range of products for protection, control, measurement, and supervision of generators, transformers, and power lines. Relion product range meets the requirements of IEC 61850 standard.

The 24 analog inputs of devices that we use ensures main and redundant protection with a single product. Alternatively, protection of additional elements such as transformers can be included to the protection scope of generators. In addition to cost saving advantage, using less products reduces the amount of installation and maintenance work.

These devices offer injection based 100% protection of stator and earthing faults and 3rd degree harmonic based 100% protection of stator and earthing faults. Secure operation is ensured even in low loads.



EXCITATION SYSTEMS

Excitation systems have significant effects on dynamic performance of generators. Quality of generator voltage and reactive power, as well as quality of energy distributed to all electric end users are all determined by excitation systems.

There are various excitation systems:

- Brushless excitation systems
- Rotary excitation machinery and automatic voltage regulator (AVR)
- Static excitation systems (SES) feeding rotors directly over brushes with thyristor bridge.

The main function of excitation system is to provide variable DC current having short-period excess load capacity, control output voltage having proper accuracy, guarantee stable operation, communicate with power plant control system and ensure operation of generator within operating limits.

In systems installed by Lagos Energy, we use ABB's UNITROL series microprocessor based voltage regulators with rotary excitation and static excitation systems for controlling of any type of synchronous machinery (motor and generator).

UNITROL® includes automatic voltage regulators (AVRs) and static excitation systems (SEs) that can be used in any size synchronous generator and motor.

Advantages

- Customer-oriented standardization
- System solutions tailored to customer needs
- Compliant with ISO 9001/ISO 14001 quality management systems
- Worldwide commissioning and maintenance services
- Quick commissioning and maintenance time with user friendly software tool





STATIC STARTER SYSTEM (FOR GAS TURBINES)

Gas turbines need boosting for reaching ignition point (60% of nominal speed). For gas turbines over 40MW, this can be achieved with two different methods.

- Pony motor with gears on main shaft
- Static frequency converter (SFC that directly connects to generator terminals and enables operation of the generator as an electric motor at the beginning of the phase.

Static starter enables acceleration of the generator smoothly without any vibration or voltage drop. Also, it helps deceleration of the generator smoothly. A single SFC can operate several generators connected in-line.

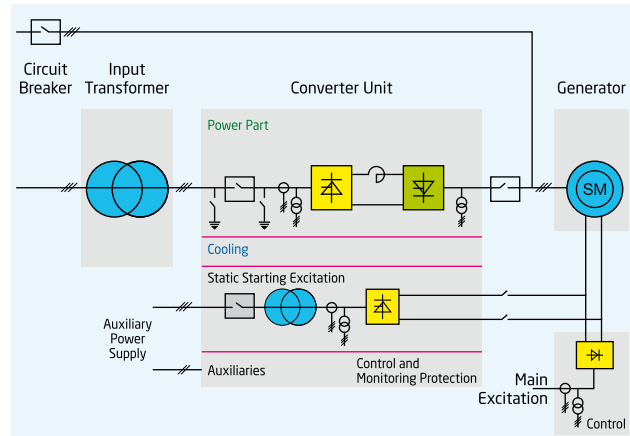

MEASUREMENT

In power plants, measurement equipment with high level of sensitivity determines how much energy is supplied to customers from the production field. Measured values are current, voltage, active and reactive power. These values are used for pricing energy consumed and obtaining statistical data.

NETWORK CONNECTION AND POWER QUALITY

The reliability and quality of energy being produced is indeed very important. Simply put, quality of energy is protection of rated value of amplitude and frequency of voltage and sinusoidal character of the wave in any point on the network. Since electric power needs to be continuous and can not be stored on the consumer side, it is not possible to provide any assurance of quality

Therefore, the energy generated should be reliable and in high quality. Unfortunately, power generated in high quality from the generators cannot be transmitted to the consumer keeping its initial quality. After generation phase, connection of electric power to the grid should also be performed in a way to keep maximum quality.

Primary frequency control

Primary frequency control (PFK) service enables bringing system frequency to a new balance point by means of automatically increasing or decreasing active power output of the unit via speed governor, in reaction to decrease or increase in system frequency. In other words, when system frequency decreases below 50 Hz, active power production is increased via speed governor located in the turbines and frequency is stopped at a value below 50 Hz. (e.g. 49.70 Hz). Bringing the frequency stopped at this value to its former value (50 Hz) will be possible with secondary frequency control. Power plants have redundancy for such purposes.

Performance Verification Technical procedure regarding primary frequency control performance test procedure is explained in Annex 17.A of the Electricity Market Grid Regulations. Prior to starting performance tests, it is expected from the employees of production facility to submit simplified block diagram of control systems of the unit and operation between turbine speed governor and control system.

During primary frequency control performance tests, the following values are measured and recorded along with other values deemed necessary by the testing team:

- Active Power Output (MW)
- Network Frequency
- Simulated Frequency
- Valve Positions
- Steam Pressure (TEPP)
- Steam Temperature (TEPP)

During primary frequency control performance tests, sampling rate of measurement made for each value should be 10 data points per second.

Primary frequency control performance tests consist of three stages:

- 1- Primary Frequency Control Reserve Test
- 2- Primary Frequency Control Sensitivity Test
- 3- Primary Frequency Control 24 Hours Verification Test





Secondary frequency control

Secondary frequency control service is needed when the system frequency increases or decreases in order to bring to nominal value and to the programmed value for exchange of total electric power with interconnected electric grids.

Performance Verification Secondary frequency control verification consists of two stages: These stages are pre-qualification test of secondary frequency control to be performed in production units, and secondary frequency control performance test to be performed over Automatic Generation Control (AGC system in National Load Dispatch Center. AGC System/Interface functions will be checked in generation unit that will participate in secondary frequency control according to the setting values sent by Automatic Generation Control (AGC) program located in National Load Dispatch Center.

It is checked if the "PD Validity" signal sent periodically by AGC program to generation unit via SCADA System is being correctly used and in case such signal is not received for a certain timeout period (60 seconds a LRPD alarm is generated in the power plant; and Automatic Generation Control System/Interface switches from REMOTE to LOCAL and switching back to REMOTE

position can only be possible by operator intervention after receiving "PD Validity" signal.

The following items are checked if they are displayed in Automatic Generation Control System/ Human Machine Interface installed in generation unit:

- AGC control block diagram
- Operation mode of AGC system
- Setting value and distribution to units
- Local setting values (Operator intervention is possible)
- Secondary frequency control limits based on unit (Operator intervention is possible)
- Maximum and minimum capacity values of secondary frequency control of generation unit (MAXC and MINC)
 - Generation unit secondary frequency control band
- "PD Validity" signal state
- Alarms regarding AGC System/Interface
- Total primary reserve
- Primary frequency control participation state (PFCO) signals for units
- Load ramp up/down speeds of units
- Speed governor droop setting - Total power plant generation
- Control error (difference between setting value and power plant generation)

In addition to records captured in power plants during generation unit secondary frequency control tests, the following values will be recorded from SCADA system by TEİAŞ National Load Dispatch Center:

- Setting values sent by National Load Dispatch Center
- System frequency value
- Active power generation of power plant/block/unit
- Active power generation of units (when necessary)

Maximum reaction time should be 30 seconds in order to start changing power output of generation unit which provides secondary frequency control service, and it

should reach required generation level according to the loading speed determined as result of tests. Loading speed of units providing secondary frequency control service should be as follows depending on the fuel type:

- At least 6% of nominal power per minute for diesel oil, fuel oil, and natural gas generation facilities
- Between 1.5% and 2.5% of nominal power for hydroelectric generation facilities with reservoir
- Between 2% and 4% of nominal power for generation facilities using hard coal as a fuel
- Between 1% and 2% of nominal power for generation facilities using lignite as a fuel

Reactive power control

Reactive power is required for operation of all devices that need the effect of magnetic field. Reactive energy is needed for all devices (e.g. electric motors etc.) particularly for transformers operating with magnetic field. However, transferring reactive energy to energy transmission lines by producing in generation facilities causes limitation on active power that a line can carry, and consequently decrease on the line capacity due to the reason that reactive energy occupies space just as active energy on transmission lines do. Consequently, reactive power factor should be kept at levels determined by regulations.

Performance Verification

Operation in over-excitation: Means reactive power is delivered to the system by the generator.

Operation in under-excitation: Means reactive power is drawn from the system by the generator.



Power quality analysis

Electricity produced at the plant sustains losses and quality is compromised until delivered to the consumer. Irregular use of transformers and cables from generation facilities to the consumer as well as use of illegal connections to the network inevitably affect quality and dependability. Therefore, it is very important to ensure top-quality electricity distributed from the power plants.

Quality of power in simple terms is protection of rated value of amplitude and frequency of voltage and sinusoidal character of wave in any point on the network. Fluctuations in voltage amplitude, power interruptions, changes like pulses, harmonics, frequency changes, flicker, three-phase imbalances are the primary known reasons for power quality losses.

Loads that take non-sinusoidal currents from the network cause severe harmonic pollution in transmission and distribution systems and creates line voltage drops causing disturbance of voltage waveform. Potentially problematic points should be prevented during grid design or points presenting danger should be identified by making risk estimations.

In order to create solutions to increase the quality of energy generated, the reasons for lack of quality should be identified, the occurrence times should be determined and this data should be used to create classifications. By measuring power quality, different parameters such as voltage and current changes can be recorded and necessary precautions can be prepared based on the results of such measurements; consistency of the system can be ensured, and great commercial benefits can be obtained by preventing non-scheduled power cuts. Continuously monitoring the network enables obtaining necessary data required for statistical analysis of problems seen in power systems. This will allow determining the precautions for future.

Compliant standards

- IEC 61000-4-30: Power quality measurement methods, Class A
- IEC EN 61000-4-7: Harmonic measurement manual
- IEC EN 61000-4-15: Flickermeter
- EN 50160: Voltage Characteristics of Electricity Supplied by Public Distribution Systems

Features of the software

- FFT analysis
- Vectorscope, oscilloscope
- Power and energy monitoring
- Voltage monitoring with EN 50160 Flickermeter
- Symmetrical component analyzer for 3 phase systems
- Power network impedance analyzer-Semi periodical RMS monitoring
- Transitive log device and fault log device
- Voltage telegram and alarms-Digital inputs



MCC PANEL SOLUTIONS

MCC panels are panel systems where engine main feeding units and control devices are located.

Control devices such as PLC and DCS and other devices required for SCADA and communications infrastructure are found in control section of the MCC panel.

Panels are important components of the system and are supplementary in projects we implement. For all systems that we install, Lagos Energy can produce type-tested distribution panels including form 4-B, MCC Panels (Motor Control Panels) and Motor Driver Panels up to 400 KW within our own capacities.

In accordance with IEC 60439-1 standard, we separate functional sections from each other within the panels with form applied LV Distribution and MCC panels, in order to increase the safety of personnel and facilities.

For custom applications, we can produce panel applications with IP66 protection class as well as UL50 certified panel applications in accordance with American standards. We use RAL7035 and RAL7032 colors as standard.

We use custom-designed bus systems for power distribution systems and especially MCC panels.

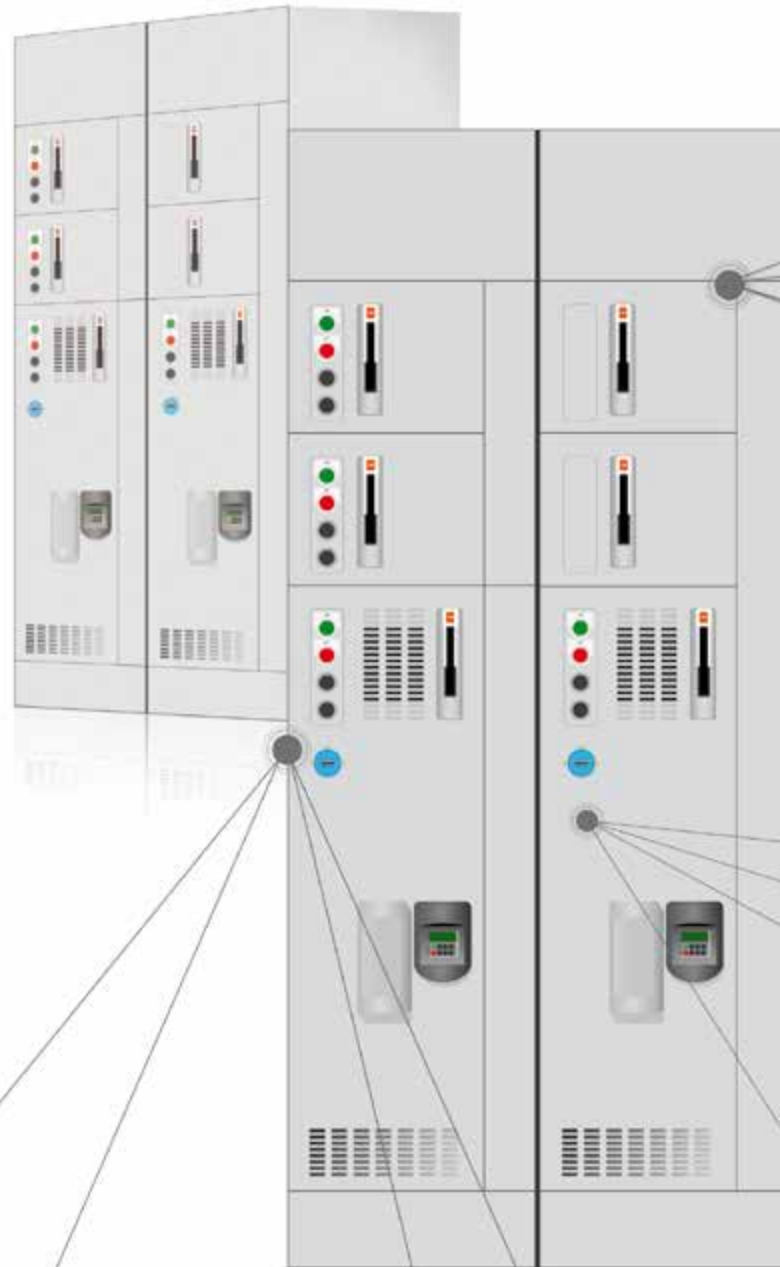



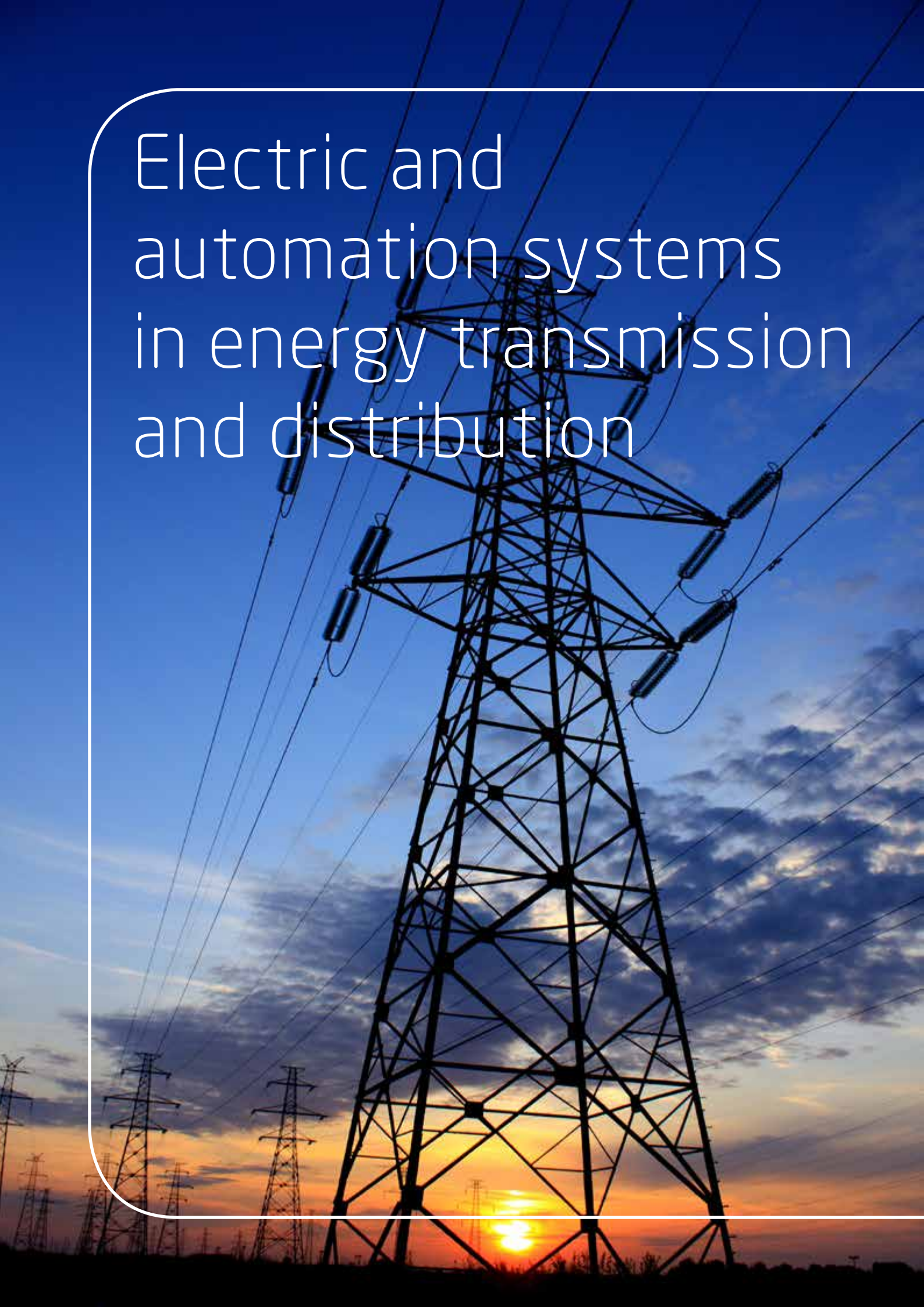

Electric and automation systems in energy transmission and distribution

Switchyards enable transmission of energy generated with quality electric infrastructure and automation, in an uninterrupted and secure way with minimum losses. Monitoring and control of the status of LV switches and power supplies, all MV circuit-breakers and disconnectors in main and sub-stations of distribution systems, monitoring the whole switchyard from a single central point controlling via SCADA are essential for security and continuous operation of the system.

Protection and control solutions we use in our systems are products that we choose for secure power transmission and distribution. ABB's Relion product family provides the broadest product range for protection, control, measurement and supervision required for IEC and ANSI applications in power systems. Specific solutions have been used for various applications such as transformer protection, line protection and breaker protection.

Main elements forming the system

- Transformers
- High voltage panels
- Medium voltage panels
- Medium voltage relays
- Medium voltage breakers

Main applications

- Transformer protection
- Line protection
- Breaker protection
- Power system automation

System architecture

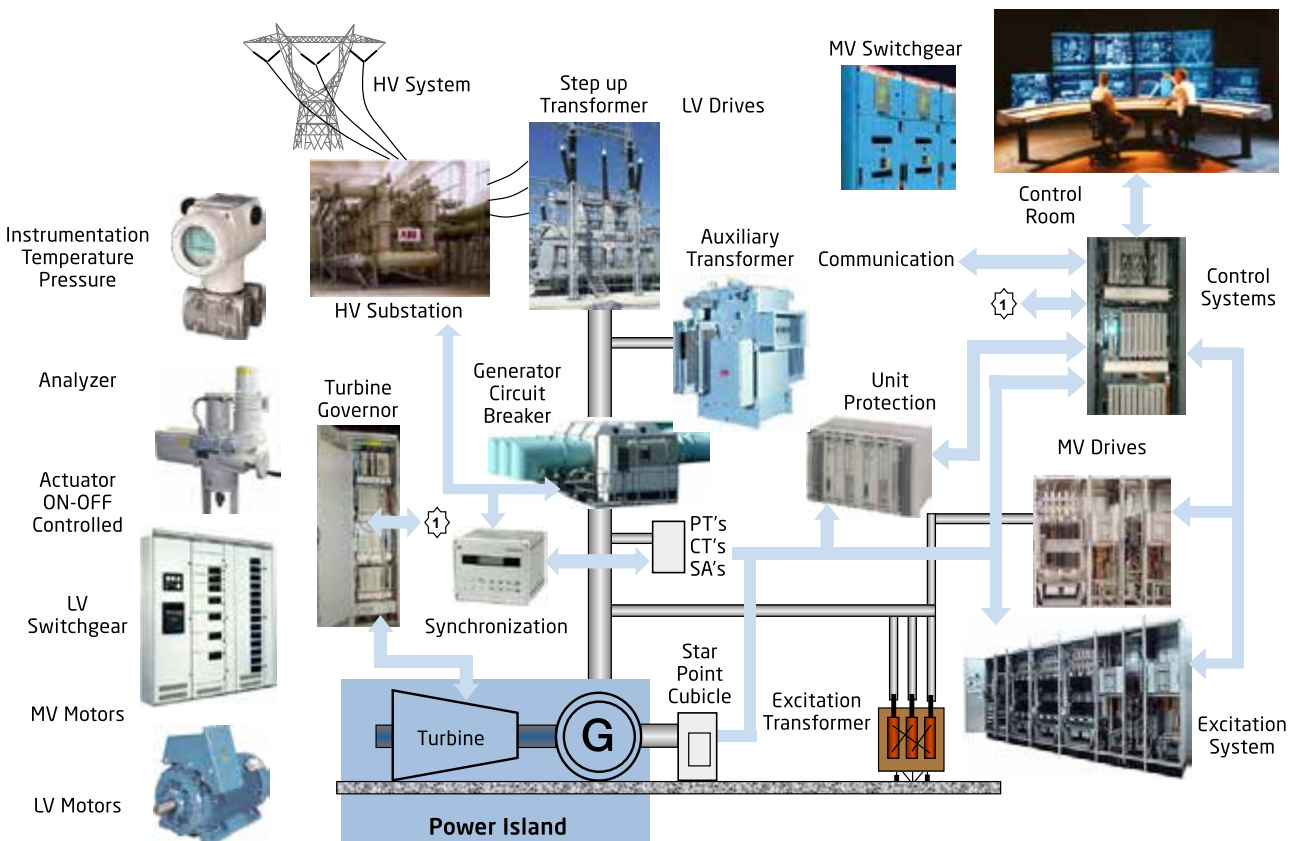

AUTOMATION SYSTEMS IN ENERGY TRANSMISSION

SUBSTATION AUTOMATION UP TO 500KV

Substation automation includes power control systems in substations, signal measurement, protection as well as remote management devices and functions intended for transferring field data into central station. In order to perform control operations in a reliable way, state of the switchyard should be continuously monitored. This means reliable products and secure communication with control center are essential.

The technological advancements allow the use of distributed control systems in switchyards instead of central control. The most important elements of this system are relay systems called intelligent electronic devices (IEDs). Basic needs such as protection, control, monitoring and communication can be handled by intelligent electronic devices.

Functions

- Monitoring and controlling states of all LV switches and power supplies, all MV switchgears and breakers in all main and sub-systems of the distribution system
- Configuration of SCADA software for monitoring and control of all stations from a control center
- Monitoring measured values (active, reactive energy, current, voltage, frequency, etc.), events, alarms, recording and displaying event dates, reporting and energy management

System architecture

- Control systems
- SCADAs
- RTUs
- IEC



SCADA SYSTEMS FOR SUBSTATIONS

SCADAs allow controlling the power transmission and distribution systems at anytime from any point. Real-time monitoring helps controlling and monitoring of primary and secondary equipment in energy transmission and distribution sites. Intelligent electronic devices can easily and securely be protected and controlled via an operator panel.

Accurate and reliable information is critical for proper and safe operation. ABB's SCADA systems we employ in systems we install maximize access to information by means of communication with the whole infrastructure and redundant system servers. SCADAs ensure the safety of personnel in many different ways. For example, breakers and disconnectors are located in a separate control room in order to prevent personnel injuries. When maintenance work is performed inside these rooms, activity can be monitored from SCADA and operators are informed that such activity is in progress. Different access authorization levels can be defined to prevent undesired interventions.

SCADA prevents sudden operation of primary equipment and tests whether the selected equipment can be operated safely or not prior to executing the command. This allows for prevention of dangerous operations. Dynamic busbar coloring function ensures instant access by operator to powered, non-powered, and earthed parts of the busbar.

Features and functions of SCADA

- Controlling and monitoring primary processes
- Single-line diagram with busbar coloring
- List of events and alarms
- Trends and graphs
- Blocking lists
- System supervision
- Setting of relay parameters
- Loading and evaluation of fault log files
- Monitoring power quality
- Data concentration and signal grouping
- Standard solutions, open interfaces, and protocols for integration of 3rd party intelligent electronic devices
- Adaptation of customer specific needs: displays, signal processing, etc.
- Integrated online configuration tools
- GPS time synchronization
- Multi language support
- Multi level user authorization
- High performance
- Operation over remote workstations and via web
- Standard PC hardware and Microsoft Windows operation system
- Master protocols: LON, SPA, IEC 61850-8-1, IEC 60870-5-101, IEC 60870-5-103, IEC 60870-5-104, RP 570/571, DNP 3.0 Serial/LAN, Modbus RTU, Modbus TCP/IP, ANSI X3.28 FD/HD, Modbus TCP/IP, I35/P214, ADLP 180, RCOM
- Slave protocols: IEC 60870-5-101, IEC 60870-5-104, DNP 3.0 Serial/LAN, RP 570/571, F4F (Westinghouse)
- Open interfaces: OPC DA client S server, ODBC client, DDE client
- Programming interfaces for application and communication additions
- OPC



REMOTE MONITORING AND CONTROL TECHNOLOGY (RTU)

Power systems can be remotely controlled via RTUs (remote terminal units) with flexible and modular design. Lagos Energy uses RTU560 series by ABB that can be mounted on DIN rail. Open architecture of RTUs enable excellent adaptation to scalability of power systems and ensures expansion in various applications.

RTU supports integrated serial and Ethernet communication. RTU permits communication with up to 16 host systems through different protocols. Standard protocols supported by RTUs include IEC 60870-5-101/-104- DNP3, serial and TCP/IP- Modbus serial and other special protocols such as TCP/IP, Indactic 33/35, RP570/71, and third party special protocols Telegyr TG800, Sinaut 8Fw, Conitel 300, Estel, Harris 5000/6000, Hitachi, and etc.



Advantages provided to the system by RTU

- RTUs' flexible and modular structure provide full control for integrated functions.
- Scalable structure enables station support, reinforcement and updates.
- Advanced diagnostics tools decrease operating and maintenance costs.
- PLC and network component functions can be performed with a single RTU system using integrated Human Machine Interface (HMI) functionality
- Single RTU solution for all systems - from complex to simple.
- Open architecture of RTU can be adapted to perform on many applications. Hardware or software additions can easily be implemented for a number of applications.
- Supports redundancy.





IEC61850 APPLICATIONS

IEC61850 is an international standard that enables integration of SCADA system with RTUs and protection relays within the same environment. In order to meet future needs and ensure reliable operation, the systems in operation as well as devices used for power systems communications should be compliant with IEC61850 standard.

Systems that consist of devices compliant with IEC61850 ensure secure operation under most demanding environments without compromising performance and ensure continuous and high quality energy in the system.

IEC61850 integrates IEC60870-5-101 communication protocol defined between telecontrol control center and station RTU, and IEC60870-5-103 communication protocol defined between RTUs and protection relays. The standard is based on Ethernet communication infrastructure that is widely used for its speed and cost-effectiveness. Systems compliant with IEC61850 ensure ease of integration, efficient and fast data sharing and cost effectiveness and meet a wide spectrum of communication needs.

At Lagos Energy, all systems we install are configured in accordance with IEC61850.

ELECTRIC SYSTEMS IN POWER TRANSMISSION AND DISTRIBUTION

PROTECTION ON ENERGY TRANSMISSION AND DISTRIBUTION LINES

To assure reliability of the system, it is important to detect faults at any point on the power transmission and distribution lines immediately. Systems in use should be sensitive enough to detect even the smallest fault current, ensure safe operation under severe outdoors environment, and comply with the IEC61850 standard. We install Relion protection and control equipment by ABB to provide maximum safety with critical operating characteristics.





Protection applications in transmission lines

Bay Control

Provides controlling, monitoring and protection functions for ground switches of circuit breakers and disconnectors in various switch configurations. Products have been extensively used in a wide array of applications. They meet the requirements of IEC61850.



Busbar Protection

Ensures busbar, mesh corners and T-connections protection and monitoring from medium voltage up to very high voltage levels. Single or double busbars are protected with circuit breakers with or without transfer bus through wide I/O capacity.



Line Differential Protection

Protection, monitoring and controlling of aerial lines and cables up to five lines. Secure single/double/three phase opening/closing and synchrocheck automatic closing can be performed with line differential protection function divided into phases for products used. Additionally, transformer feeders, generators and transformer blocks can be controlled.



Transformer Protection

Quick selective protection, monitoring and control are provided for any type of transformer (e.g. two and three wound transformers, step-up transformers, power stations and special railway transformers). Additionally, protection can be performed together with switching for autotransformers, phase-shifting transformers, and shunt reactors. Multi breaker transformer arrangement can be made with up to six three-phase current limiting inputs that are within differential protection. Communication capability allows integration with other devices in the system or use as a standalone component.

Breaker Protection

Breakers can be protected individually in areas where breaker fault protection or automatic reclosing function is not suitable or not preferred within main line protection. Additionally, redundancy protection, synchronization, synchronization control and energizing control features allow secure protection for a number of applications.



Wide Area Protection

Effective and real-time controlling, monitoring and protection of power systems spread in a wide area is achieved. These products provide AC voltage and current to power systems as phasor (up to 8 analog phasors including positive, negative, zero transitive, or all). Ability to measure voltage and current at high precision eliminates the need of external measurement transducers. IEEE C37.118, IEC 61850-8-1 and DNP3.0 communication capacity facilitates integration into existing infrastructure system. Various protection and control functions can be performed with phasor data measurement function. Excellent solutions are provided for smart network applications.

Line Distance Protection

A wide range of protection features can be achieved for aerial lines and cables or aerial lines and cable combinations. A complete distance protection is ensured with selective single phase and three phase opening/closing, synchronous and synchro-checked automatic shutdown, power fluctuation detection and wide communication logic. Transmission lines, cables or grounded networks can be protected by five region distance protection for phase-to-phase, phase-to-earth faults. These products also have overcurrent protection and communication feature.

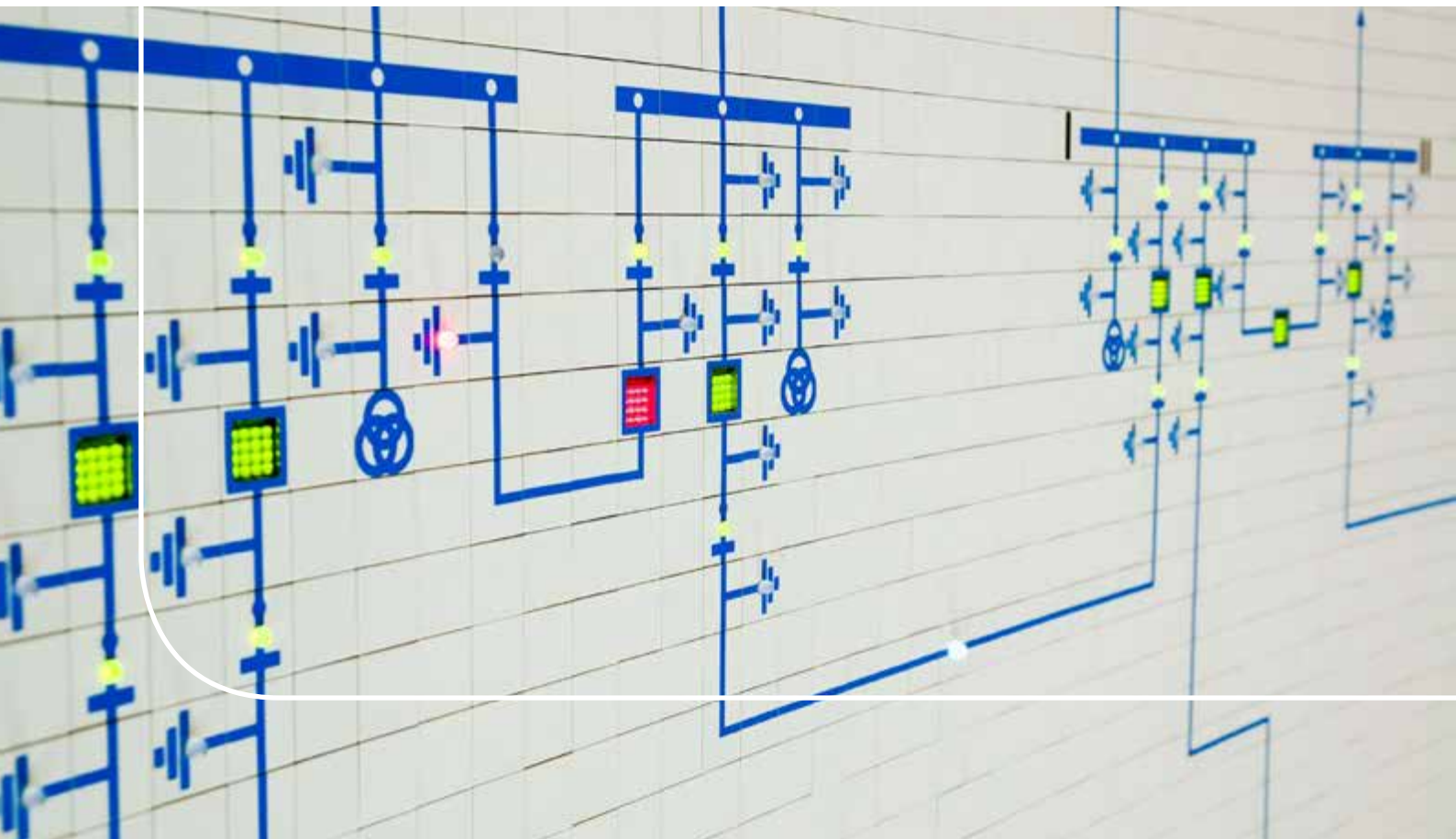



Electrical protection in rail transportation

Protection relays and control panels specifically developed for rail transportation systems provide any type of protection, control and monitoring function.

Designed by employing state-of-art numerical technologies, protection panels provide feeding protection function as well functioning as protection relays for transformers. With large LCD display and communication port, relays enable monitoring and controlling critical important values such as current/voltage/power factor.

Functions

- Digital distance protection
- Instantaneous overcurrent protection
- Phase discordance order protection
- EMI/EMC noise analysis
- Fuse fault detection
- Automatic reclosure
- Circuit fault detection
- Breaker failure supervision
- Transformer protection
- Unbalanced current protection





Protection applications in distribution lines - MV

We provide infrastructure for any type of protection, control, monitoring and communication requirements of distribution systems from secondary infrastructure to NCC level. We achieve this by protection and control products compliant with IEC 61850 standards. These protection and control devices make it possible to collect, measure and report smart network elements supporting power systems and investment management systems.

Applications

- Alarm reporting
- Breaker protection
- Disturbance record devices
- Network line protection and control
- Line differential protection
- Arc protection
- Network automation
- Motor protection
- Transformer protection



Primary / Secondary Field Performance Tests

Performance tests we perform to determine switchyard compliance with quality standards are classified as follows:

Secondary Protection Relay Tests

- 1- Overcurrent relay tests
- 2- Voltage relay tests
- 3- Line distance protection relay tests
- 4- Line differential protection relay tests
- 5- Transformer & busbar differential protection relay tests
- 6- Engine protection relay tests
- 7- Generator protection relay tests
- 8- Breaker fault protection relay tests

Power Transformer Tests

- 1- Ratio tests
- 2- Winding resistance measurement test
- 3- Insulation test
- 4- Zero sequence impedance test
- 5- Short circuit voltage test
- 6- Copper/iron losses test

Tests for High Voltage Line Feeders

- 1- Line parameter tests
- 2- Zero sequence impedance tests
- 3- Positive sequence impedance tests

Current Transformer Tests

- 1- Ratio tests
- 2- Load test
- 3- Winding resistance measurement test
- 4- Saturation test
- 5- Insulation test
- 6- Polarity tests

Voltage Transformer Tests

- 1- Ratio tests
- 2- Insulation test
- 3- Polarity test

Breaker Tests

- 1- Opening-closing time measurement test
- 2- Contact resistance measurement test
- 3- Insulation test

Disconnecter Tests

- 1- Contact resistance measurement test
- 2- Insulation test



TEİAŞ RTU COMMUNICATION IN POWER PLANTS

Within the scope of TEİAŞ National Load Dispatch SCADA / EMS System Project, it is a requirement to establish a communication system between TEİAŞ SCADA system and power generation and energy facilities with autoproducer license (Hydroelectric Power Plants, Wind Energy Plants, Thermal Plant). Our company provides various solutions in this area such as OPGW Communication, PAX Communication, Leased Line communication, PLC communication, and RTU system.

Communication between National Control Center (NCC), Emergency State Control Center and Regional Control Center (RCC) is established using channels leased from Turk Telekom, satellite channels (VSAT) and TEDAŞ's own fiber-optic channels.

In order to increase data security, redundant communication channels are used between NCC and RCC, and between RCC and RTU. Data exchange between Regional Control Centers and RTUs is over power line carrier (PLC) channels, fiber-optics cables of TEDAŞ and channels leased from Turk Telekom A.Ş.

Data communication rate of 200, 600, 1200, 2400, 9600, and 19200 bps are used between RCC and RTUs. In Control Centers, RTU links are connected over Telecontrol Interface (TCI) in a way that can be operated as point-to-point or multidrop (party-line).

Data communication protocol used in Control Centers is IEC 60870-6 (Inter Control Center Protocol) communication protocol. For communication between RTUs and control centers, IEC 60870-5-101 communication protocol is used for new RTUs, and F4F communication protocol is used for older RTUs.

Information gathered by RTUs located in substations and power plants gets processed and sent to Regional Control Centers and from there to National Load Dispatch and Emergency State Center. Control signals sent from control centers are transmitted to power plants and substations via RTUs.

With the help of RTUs, various measurements required for monitoring and operation of National Interconnected Electric Network are gathered. These include values for generator units, active and reactive power values of lines and transformers from plants and substations, busbar voltage values, position details of transformer tap changer, measurements of current and frequency from different centers, additional data regarding plants, information on breaker, disconnector and earth disconnector for determining topology, alarm information and energy measurements.

In general, analog measurements are sent to the control center every 10 seconds if certain threshold is exceeded. State and alarm information is sent whenever there is a change in the state. Time-tag information will also be sent to the control center for state and alarm information.

RTUs send the occurrence time of state changes to the respective Regional Control Center as „time-stamp“. New RTUs have 1 milliseconds resolution and remote control for time-tagging state and alarm information. We use RTU560 device from ABB in systems we install.

We provide solutions for all communication requirements over TEİAŞ OPGW cables. With their advantageous price/performance ratio and a long list of successful references, UMUX and XMP products which offer SDH and PDH on a single chassis are preferred solutions in TEİAŞ OPGW projects.







İvedik Mah. 1495. Cad. No:3/10
Bulvar Ticaret Merkezi
Yenimahalle Ankara - Turkey
T: +90 312 442 14 54
F: +90 312 442 14 53
www.lagosenerji.com